



# WMG Series

## FEATURES

- The most requested size pump in the pressure cleaning industry.
- Five year limited warranty.
- Forged brass manifold with an exclusive lifetime warranty.
- Large capacity, die-cast, anodized aluminum oil-bath crankcase.
- Over-sized connecting rods for maximum life.
- Heavy-duty ball bearing.
- Solid ceramic plungers with mirror finish and corrosion resistance.
- Stainless steel inlet and discharge valve assemblies.
- Forged valve caps with recessed O-rings.
- Zinc coated manifold bolts for extra corrosion resistance.

## SPECIFICATIONS

PUMP MODEL	2625	2530
Maximum Volume (GPM)	2.5	3
Max. Discharge Pressure (PSI)	2600	2500
Maximum Pump Speed (RPM)	3450	
Maximum Inlet Pressure (PSI)	125	
Maximum Inlet Vacuum	Flooded	
Bore	15 mm	
Stroke	6.5	6.8
Crankcase Oil Capacity	15 oz.	
Maximum Fluid Temperature	165° F	
Inlet Port Thread	1/2" - 14 BSPP-F	
Discharge Port Thread	3/8" - 19 BSPP-F	
Shaft Diameter	3/4"	
Weight	15 lbs	
Dimensions	8.6" x 5.0" x 7.81"	

## DIMENSIONAL DRAWING

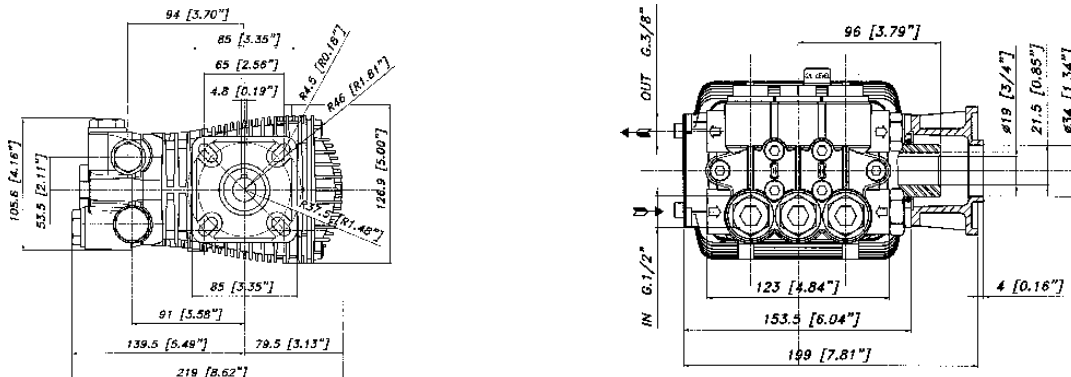

Legacy Pump • USA

# Legacy Model WMG 3/4" 2625-2530

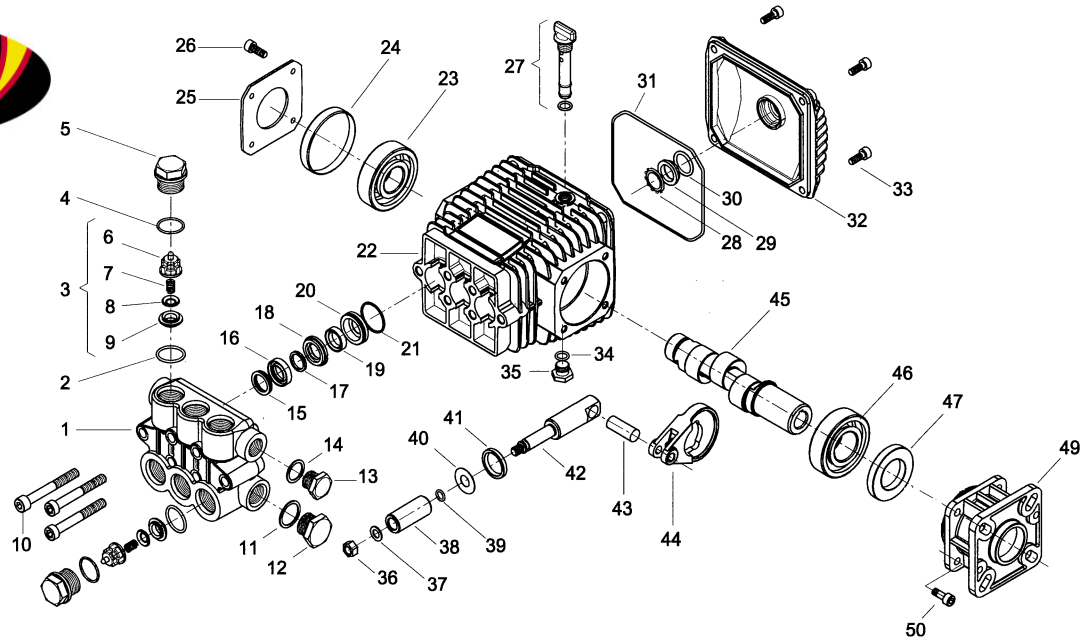

POS NO.	PART NO.	DESCRIPTION	KIT	NO. PCS.
1	15-040119282	Pump Head (D.15)		1
2	15-803182002	O-Ring Dia. 2.62 x 17.13	124	6
3	15-049887973	Check Valves	124	6
4	15-803182002	O-Ring Dia. 2.62 x 17.13		6
5	15-070040532	Ex. Deep Sealing Valve Cap M27x1.5		6
6	15-040114322	Valve Guide	124	6
7	15-040330512	Valve Spring	124	6
8	15-060068512	Valve	124	6
9	15-040023512	Valves Assembly Seat	124	6
10	15-862945002	Screw M8x60 UNI 5931		6
11	15-824140002	Gasket for Coupling 21.2 x 26 x 1		1
12	15-852629002	Plug G 1/2"		1
13	15-852579002	Plug G 3/8		1
14	15-824109002	Copper Gasket Dia. 17 x 22 x 1		1
15	15-040270322	Seal Packer	68, 73	3
16	15-802020002	Packing D.15	68, 73	3
17	15-040269322	Anti-Extrusion Ring	68, 73	3
18	15-040268532	Front Gland	68	3
19	15-802034002	U Pressure Seal Dia. 15 x 22 x 5.5	68, 73	3
20	15-040166532	Packing Retainer	68	3
21	15-803073002	O-Ring Dia. 23.52 x 1.78	68, 73	3
22	15-040110092	Crankcase		1
23	15-812725002	Bearing Riv 6B 25		1
24	15-802101002	Cap RCA 6210		1
25	15-050045612	Crankcase Cover		1
26	15-862108002	Screw M6x16 UNI 5931		4

POS NO.	PART NO.	DESCRIPTION	KIT	NO. PCS.
27	15-049832973	Filler Plug		1
28	15-801184002	Ring		1
29	15-040120322	Oil Sight Glass		1
30	15-803189002	O-Ring Dia. 2.62 x 18.72		1
31	15-803210682	O-Ring D.2.62x 120.32		1
32	15-040117092	Rear Cover		1
33	15-862168002	Galvanized Screw M6x22 UNI 5931		4
34	15-803057002	O-Ring 2037 - 39.34 x 2.62		1
35	15-852543502	Cap G. 1/4 x 9 (EX852542002)		1
36	15-814561002	Stainless Steel Nut M8 UNI 5589		3
37	15-843642902	Washer Dia. 8.1 x 14 x 1		3
38	15-040010182	Ceramic Piston Dia. 15 mm		3
39	15-803049002	O-Ring Dia. 1.78 x 5.28		3
40	15-843726002	Washer Dia. 9.1 x 24 x 1		3
41	15-802035002	Oil Seal Dia. 15 x 24 x 5	64	
42	15-040107512	Plunger Rod		3
43	15-852003002	Piston Pin Dia. 8 x 25		3
44	15-040115092	Conrod		3
45/1	15-040246262	Hollow Crankshaft 3/4" E=3.6 (2530)		1
45/0	15-040123262	Hollow Crankshaft 3/4" E=3 (2625)		1
46	15-812750002	Ball Bearing 30 x 62 x 16		1
47	15-802125502	Shaft Oil Seal		1
49	15-040329092	Motor Flange SAE 3/4		1
50	15-862108002	Screw M6x16 UNI 5931		4

	KIT 124 CHECK VALVE/O-RING	KIT 64 PLUNGER OIL SEAL	KIT 68 PACKING/ BRASS ASSY	KIT 73 PACKING ONLY
<b>KIT BREAKDOWN</b>				
<b>PART #</b>	15-049890973	15-049836973	15-049840973	15-049843973
<b>TOTAL PCS.</b>	12	3	21	15